

MODULINE COLORSCREEN FENCING



Gate Assembly and Installation

Moduline Colorscreen gates can be assembled in any width from 0.83m to 1.55m. The simplest widths are made using complete duo panels, as follows:

GATE WIDTH(m)	0.83	1.07	1.31	1.55
No. OF DUO PANELS	3	4	5	6

Gate widths between these are achieved by trimming one length of duo panel to the required width (see Step 2).

Gate stiles are available in various heights to match the fencing.

Components -

Gate stile	2
Rail	2 (cut from full rail)
Duopanel	3-6
50mm sq black cap	2
Tek screws painted	30-34
13mm angle	2-4 (depending on gate height)

Assembly

PLEASE NOTE When cutting Colorsteel use a hacksaw or tinsnips. **DO NOT USE** an angle grinder or abrasive cutoff blades

Step 1 - Cut rail to required length. (width of gate less 102mm). Ensure this cut is square and file the burrs off. Wipe clean with a soft cloth.

Step 2 - If a whole number of duopanel will not fit, you will need to trim a duopanel to the make up the desired width. This can be achieved in one of three ways :

- (A) The easiest and neatest option is to score with tungsten Hardies scoring knife and hand fold the Duo Panel which will then snap off at the scored width. Hardies Scoring knives are available for around \$10 from most hardware outlets.
- (B) Take the Duo Panel to your local sheet metal workshop for guillotining.
- (C) Cut down with tin snips, the cut edge will be hidden by the 13mm angle.

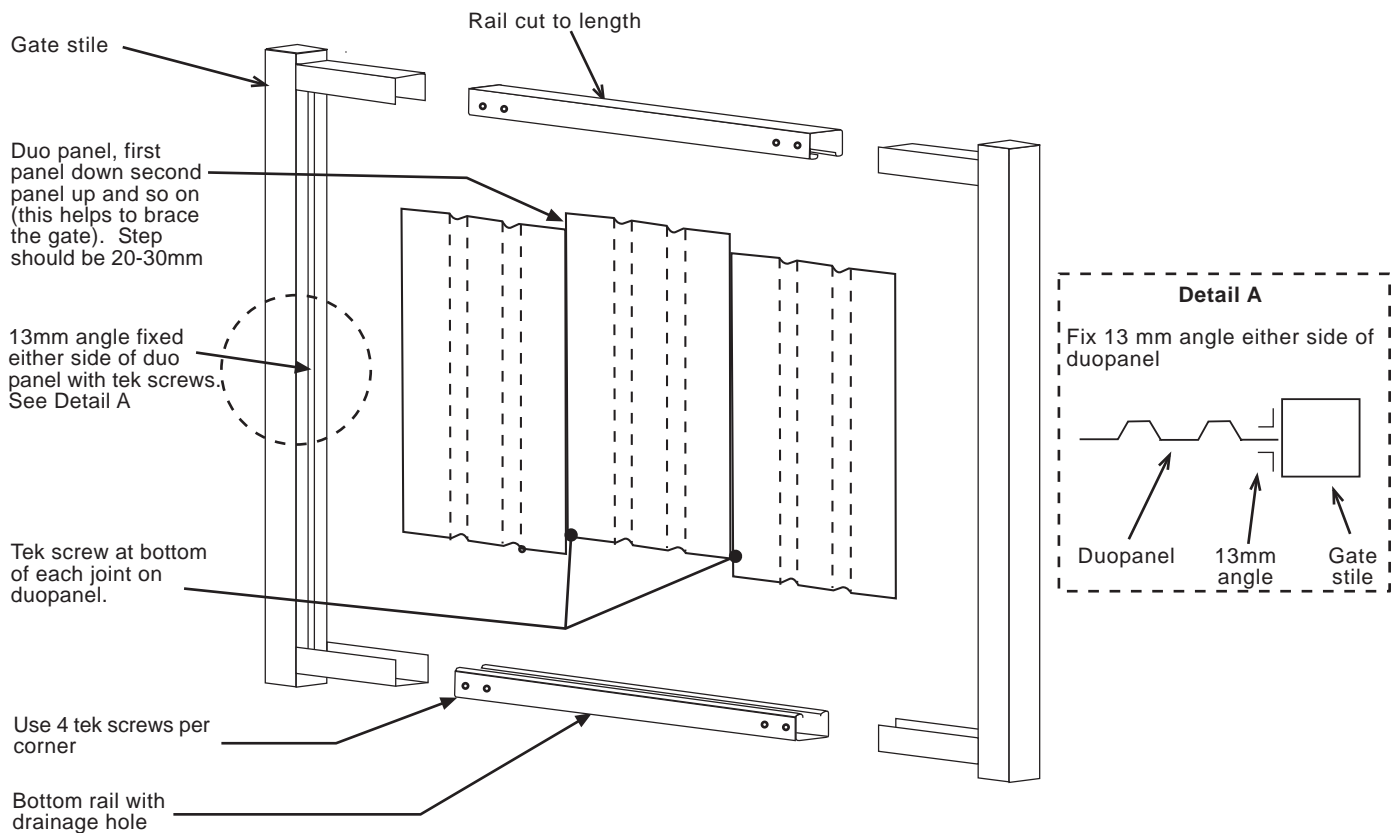

METAL ROLLFORMING LIMITED

PO BOX 18-217, AUCKLAND 1743, PHONE (09)527-7897, FAX (09)527-7896

Gate Assembly and Installation continued

C

Step 3 - Slide the duopanel together as per standard fence assembly instructions. For extra gate bracing, stagger the panels by 20-30mm as shown in the sketch

Step 4 - Assemble stiles, rails and panel then tek screw rail to gate stile channel. Ensure that the bottom rail has a drainage hole. Drill one hole 10-12mm diameter if your bottom rail does not have a factory pre-punched hole. This will be the case if the top and bottom rail are cut from the same piece.

Step 5 - Screw 13mm angle to stile either side of the duo panel as shown.

Gate Installation

Step 1 - Concrete in gate posts while installing fencing. Be sure to set posts vertical using a good level. Make sure the opening gaps are correct. Measure both at the base and tops of the posts. Make sure the top of posts are correct height above the ground, and level. Allow concrete around gate posts to harden at least over night before hanging the gates.

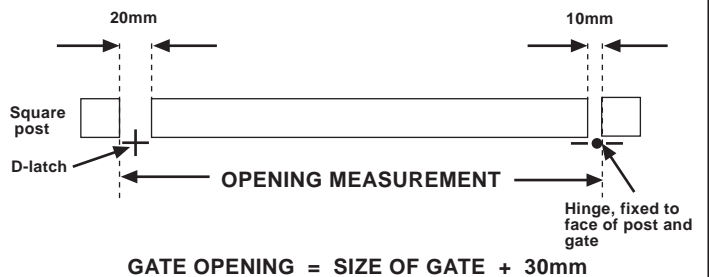

Step 2 - Fix the butt hinges to the gate first. It is recommended that the hinges be face mounted. Tek screw these on at approximately 100mm from the top and 100mm from the bottom. Use galvanised tek screws supplied.

Step 3 - Support the gate on blocks so that the gate top is level with the top of the post, use galvanised tek screws supplied. Fix the gate to the post.

Step 4 - Fix D-latch using galvanised tek screws, refer sketch.

