

Double Gate Assembly and Installation

Moduline Colorscreen gates can be assembled in any width from 0.83m to 1.55m. The simplest widths are made using complete duo panels, as follows:

GATE WIDTH(m)	0.83	1.07	1.31	1.55
No. OF DUO PANELS	3	4	5	6

Gate widths between these are achieved by trimming one length of duo panel to the required width (see Step 2).

Gate stiles are available in various heights to match the fencing.

Components -

Gate stile	2
Rail	2 (cut from full rail)
Duopanel	3-6
50mm sq black cap	2
Tek screws painted	30-34
13mm angle x 2.4 long	2-4 (depending on gate height)

Assembly

PLEASE NOTE When cutting Colorsteel use a hacksaw or tinsnips. **DO NOT USE** an angle grinder or abrasive cutoff blades. See Sheet G2

Step 1 - Cut rail to required length. (width of gate less 102mm). Ensure this cut is square and file the burrs off. Wipe clean with a soft cloth.

Step 2 - If a whole number of duopanel will not fit, you will need to trim a duopanel to the make up the desired width. This can be achieved in one of three ways :

- The easiest and neatest option is to score with tungsten Hardies scoring knife and hand fold the Duopanel which will then snap off at the scored width. Hardies Scoring knives are available for around \$10 from most hardware outlets.
- Take the Duo Panel to your local sheet metal workshop for guillotining.
- Cut down with tin snip, the cut edge will be hidden by 13mm angle

Step 3 - Slide the duopanel together as per standard fence assembly instructions. For extra gate bracing, stagger the panels by 20-30mm as shown in the sketch. Tek screw through the seams at the bottom.

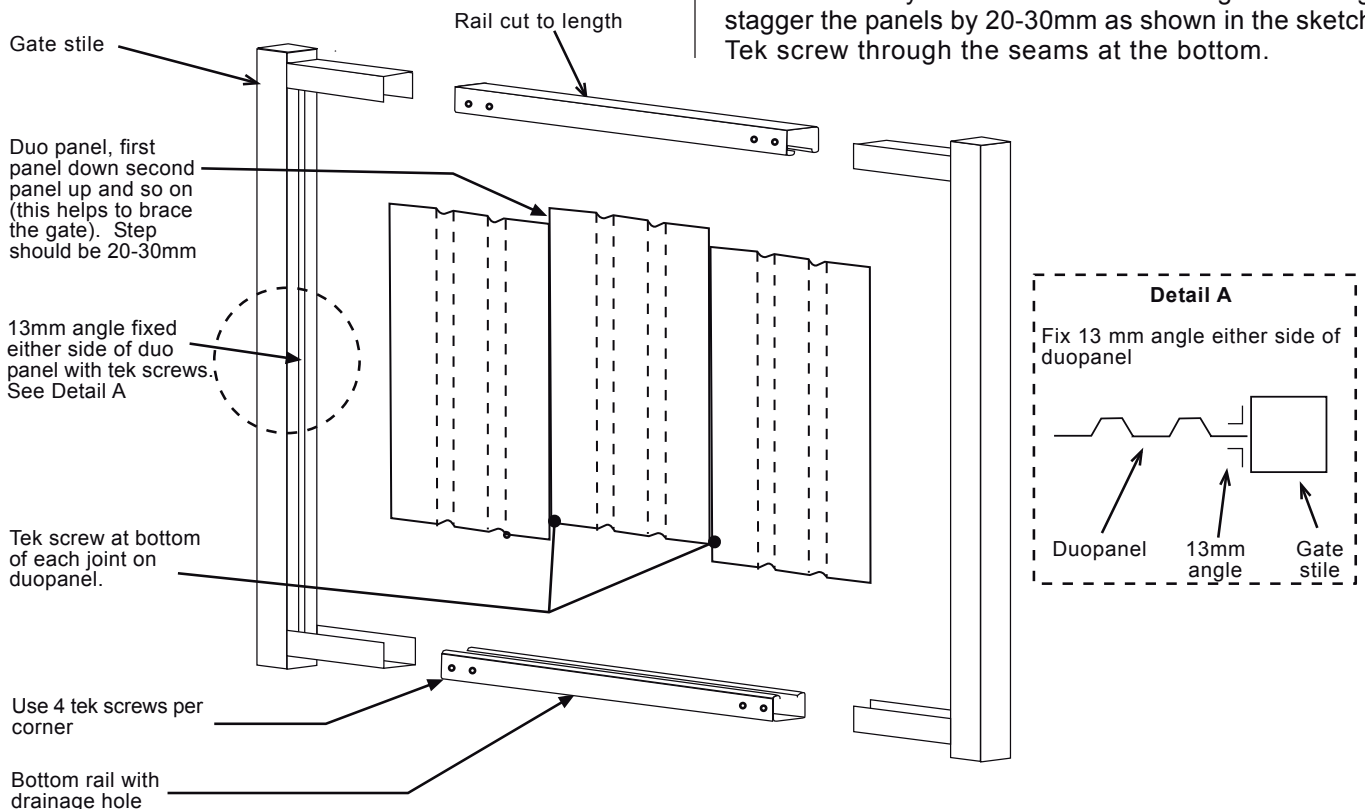

Double Gate Assembly and Installation - Cont'd

Step 4 - Assemble stiles, rails and panel then tek screw rail to gate stile channel. Ensure that the bottom rail has a drainage hole. Drill one hole 10-12mm diameter if your bottom rail does not have a factory pre-punched hole. This will be the case if the top and bottom rail are cut from the same piece.

Step 5 - Screw 13mm angle to stile either side of the duo panel as shown.

Double Gate Installation

Components -

- 2 Gate Posts 600mm longer than height of gates
- 2 Gates
- 2 Pair of stainless steel butt hinges
- 2 Long Cane Bolts
- 1 Stainless steel D-latch
- Tek screws and Caps

Step 1 - Concrete in gate posts while installing fencing. Be sure to set posts vertical and plumb using a good level. Make sure the opening gap is correct, see diagram below.

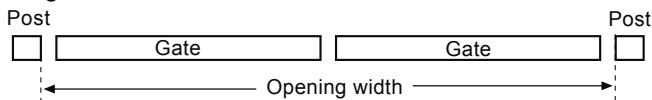

NOTE: The opening gap is critical, please check with Moduline fencing if you are not sure of the gap for your installation. Measure both at the base and top of the posts. Make sure the tops of posts are correct height above the ground and level. Allow concrete around gate posts to harden at least over night before hanging the gates.

Step 2 - Fix the butt hinges to the gate first using stainless steel tek screws approximately 100mm from the top and 100mm from the bottom. It is recommended that the hinges be face mounted. Initially fix hinges using only two tek screws per hinge.

Step 3 - Support the first gate on blocks so that the gate top is level with the top of the post. Level gate before securing and again use only 2 stainless steel tek screws per hinge.

Step 4 - Support the second gate on blocks. Ensure the centre uprights are level before tek screwing hinges. Use only 2 stainless steel tek screws per hinge initially, then check with a level before fixing remaining tek screws on all hinges.

Step 5 - Fix long cane bolts using galvanised tek screws.

Step 6 - Fix D-latch using stainless steel tek screws.

