

MODULINE COLORSCREEN FENCING **K1**

Fence Bracing

Brace as supplied

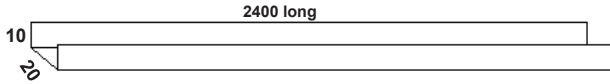

Step 1 - Flatten end of the small channel with a hammer. Bend the flattened end on a slight angle.

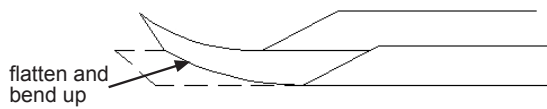

Step 2 - Take the flattened end and Tek screw to top of fence post. This hole in the post will be hidden by the plastic cap when the fence is finished.

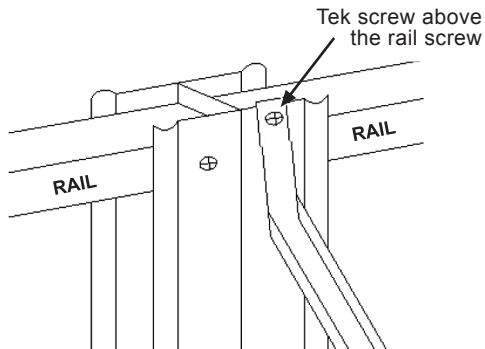

Step 3 - Drill a hole in the other end of the brace and use a tent peg to hold firm into the ground. Braces need only stay on for 1 hour, or longer if windy day.

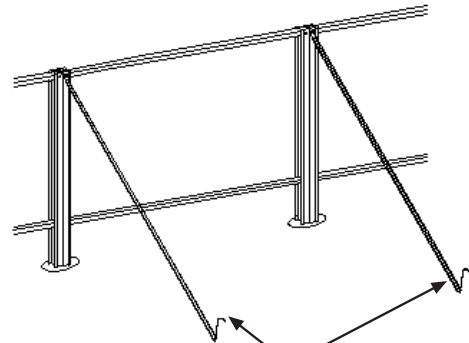

Move tent peg back or forward to plumb the fence.

METAL ROLLFORMING LIMITED

PO BOX 18-217, AUCKLAND 1743, PHONE (09)527-7897, FAX (09)527-7896