

MODULINE POOLSIDE FENCING

L2

Assembly of Fence Panels - BARS NOT NOTCHED

Components for a 2.42m panel -

- 2 x Posts
- 1 x Top Rail
- 1 x Bottom Rail
- 21 x 19mm square tubes
- 2 x Pool channels (with 19mm square holes)
- Painted or plated tek screws (self drilling)

Tools required -

- Tin snips or hacksaw
- Drill - preferably variable speed but with a small amount of practice any drill will do
- Tape measure
- Phillips no 2 bit for drill (50 to 70mm long)
- Saw Horse - 2
- Timber 75 x 50 - 2 @ 2.4m long (or longer)
- Glove

Step 1 - Place two pieces of 75x50 timber on two saw horses as an assembly bench.

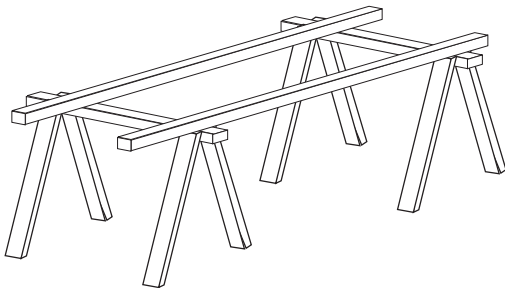

Step 2 - Lay pool channel on floor close to the wall. Push 19mm square tubes into pool channel, making sure the seams all face the same direction. Lean tubes against wall.

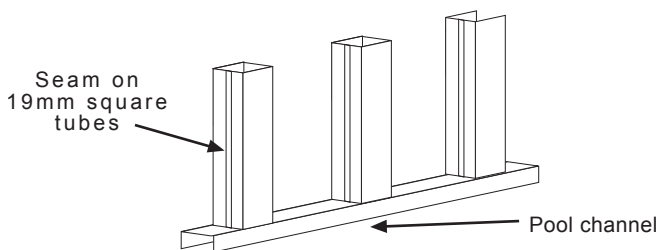

Step 3 - Lay next pool channel on top of the 19mm square tubes. Start at one end, tap the channel down onto the tubes with your palm (wear a thick glove, or use a wood block and hammer).

Step 4 - Starting at one end again, tap the channel to the finished depth of 25mm as shown.

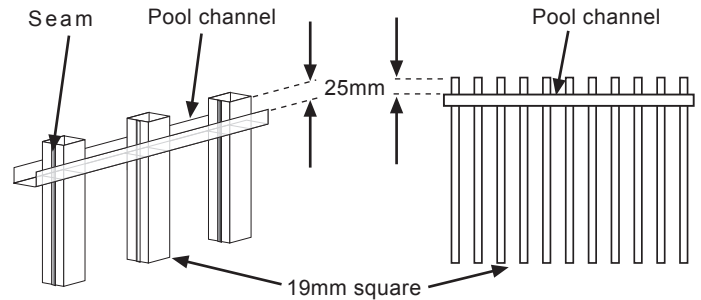

Step 5 - Flip the panel over and tap the pool channel down as in step 4.

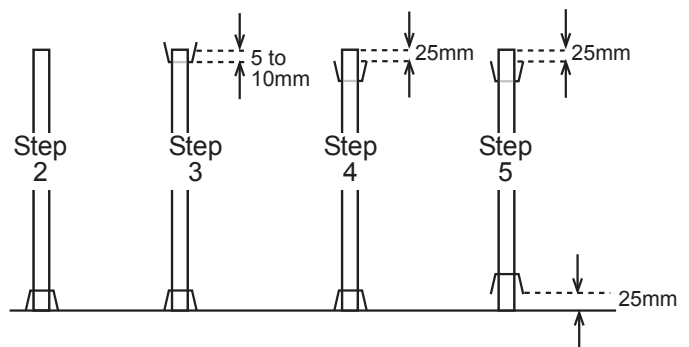

Step 6 - Lay the threaded tubes on the saw horses and slide on the top and bottom rails. NOTE the rail with drain holes goes on the bottom.

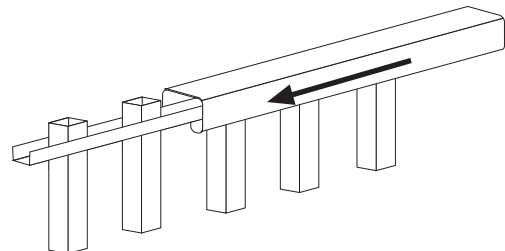

Step 7 - Push the posts over rail by gently squeezing the rail together.

Make sure the gap between the end of the rail and the inside of the post is 6mm. Set the gap at the other end by measuring the overall width as in Step 9 and NOT by using the rail as a gauge.

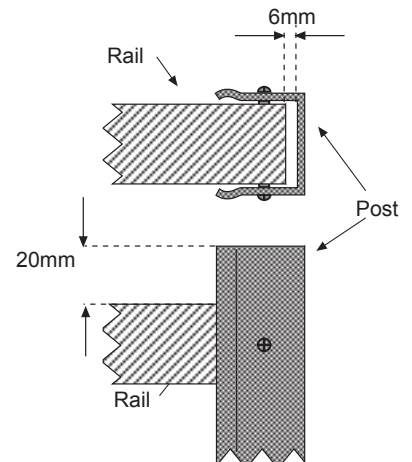

Make sure the top of the rail to the top of the post is 20mm.

METAL ROLLFORMING LIMITED

PO BOX 18-217, AUCKLAND 1743, PHONE (09)527-7897, FAX (09)527-7896

Assembly of Fence Panels continued - BARS NOT NOTCHED

L2

Step 8 - Screw the first post to the top and bottom rails with tek screws, checking measurements as in Step 7.

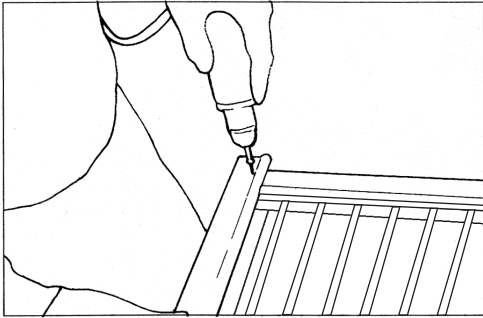

Step 9 - Check overall width is 2.42m. Secure second post as in 5 and 6 above, ensuring you check the measurements in Step 5. Turn panel over and screw in reverse side.

Panel is now ready for installation

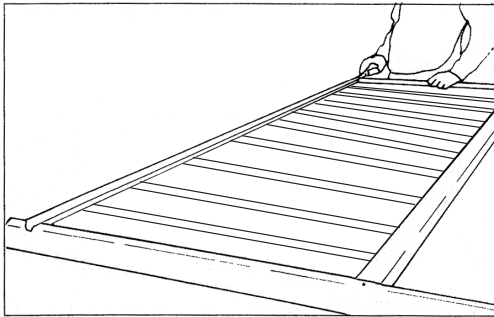

Galvanised or Heavy Duty Fencing

For galvanised or Heavy Duty tube fencing the 19mm uprights need to be secured to the pool channel using 4 tek screws as shown below.

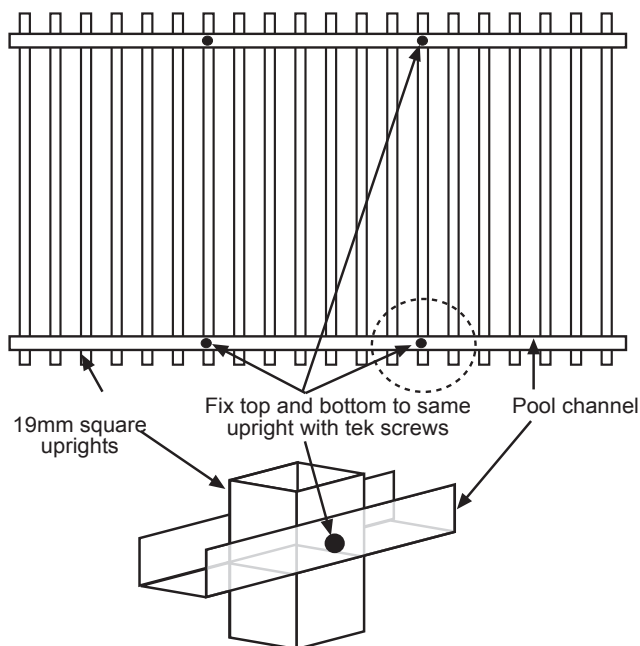

Assembling Shorter Length Panels

PLEASE NOTE DO NOT USE AN ANGLE GRINDER OR ABRASIVE CUT OFF BLADES WHEN CUTTING COLORSTEEL

Many fences will require one or more shorter length panels to make up the desired fence length. You will need to cut down the rails and pool channel to achieve this. Shorter length panels also require proportionally fewer 19mm square tubes.

Step 1 - Cut the rails to length using a hacksaw. The rail should be cut to the desired length of panel less 20mm. File the cut to remove burrs, then wipe swarf off inside and outside of rail with a soft cloth.

Step 2 - Cut the pool channel to the same length as the rail using tinsnips or a hacksaw. Ensure the amount trimmed is the same each end. File the cut to remove burrs, then wipe swarf off.

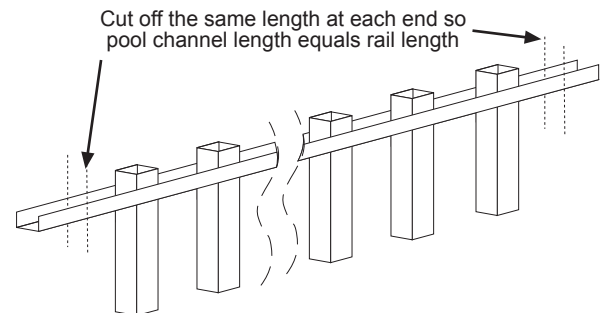

Step 3 - Assemble the panel as per the instructions for a full length panel. Obviously, you will require fewer 19mm square bars.

METAL ROLLFORMING LIMITED

PO BOX 18-217, AUCKLAND 1743, PHONE (09)527-7897, FAX (09)527-7896