

# MODULINE POOLSIDE FENCING

# R1

## Alternative Assembly of Pool Channel for Large Volumes - NOTCHED BARS

Please Note: These Instructions should be used in conjunction with Sheet L

Step 1 - Prior to commencing make a jig.

Use a length of 75 x 50 or 100 x 50 timber cut to length at 2420mm, and lay pool channel on top. Cut 22 small squares of 28mm thick board and nail each square onto the 75 x 50 spacing the blocks so as to fit between the holes of the pool channel

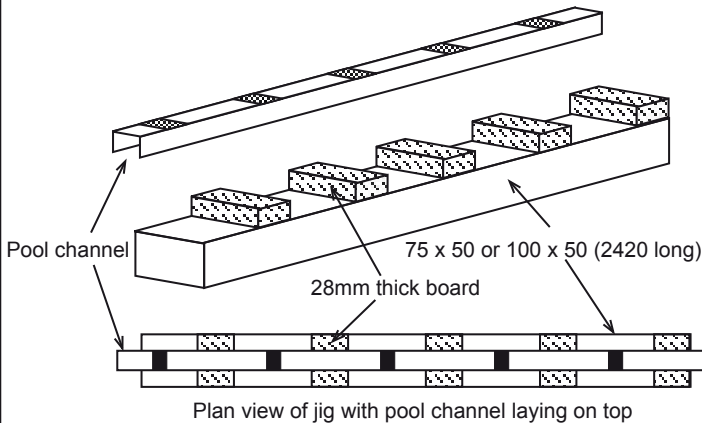

Step 2 - Fix bottom pool channel.

Press each 19mm square into the holes in the pool channel - rest uprights against wall. Make sure that seams are all facing along the fence in the same direction.

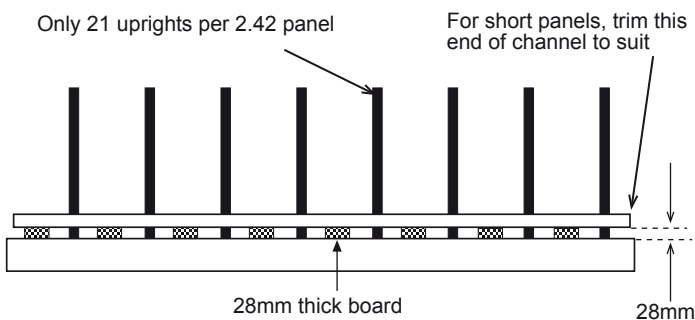

Step 3 - Fix top pool channel

Gently tap the top pool channel over ends of each 19 mm square upright. Start from one end and only fix the channel over the ends by 5-10mm.

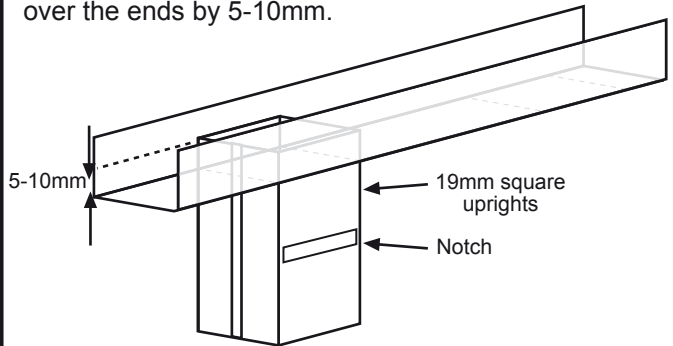

Step 4 - Use Jig upside down

Take the jig and rest upside down on the pool channel. Now gently hammer down the jig so all the squares are evenly driven through the pool channel.

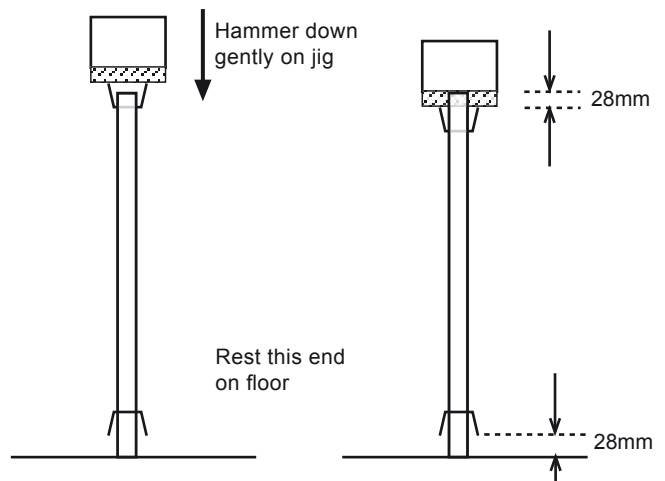

## METAL ROLLFORMING LIMITED

PO BOX 18-217, AUCKLAND 1743, PHONE (09)527-7897, FAX (09)527-7896