

# MODULINE POOLSIDE FENCING

S

## Racking Fence for a drop of over 500mm in a 2.42 panel

**PLEASE NOTE** When cutting Colorsteel use a hacksaw or tinsnips. **DO NOT USE** an angle grinder or abrasive cutoff blades

**You will also require Instruction Sheet L and M for standard Assembly and Installation**

**Step 1** - After you have assembled the panels following Instruction Sheet L, rack section of fence by pushing at the top.

**Step 2** - Now remove post from each end.

**Step 3** - Using a hacksaw, cut small sections off the rails so that they are plumb as shown on the sketch. You may also need to trim the pool channel to the same length as the rail. Wipe area with a soft cloth.

**Step 4** - Refix posts allowing a 6mm gap between the posts and the rails.

**Step 5** - Now complete racking of fence to desired angle.

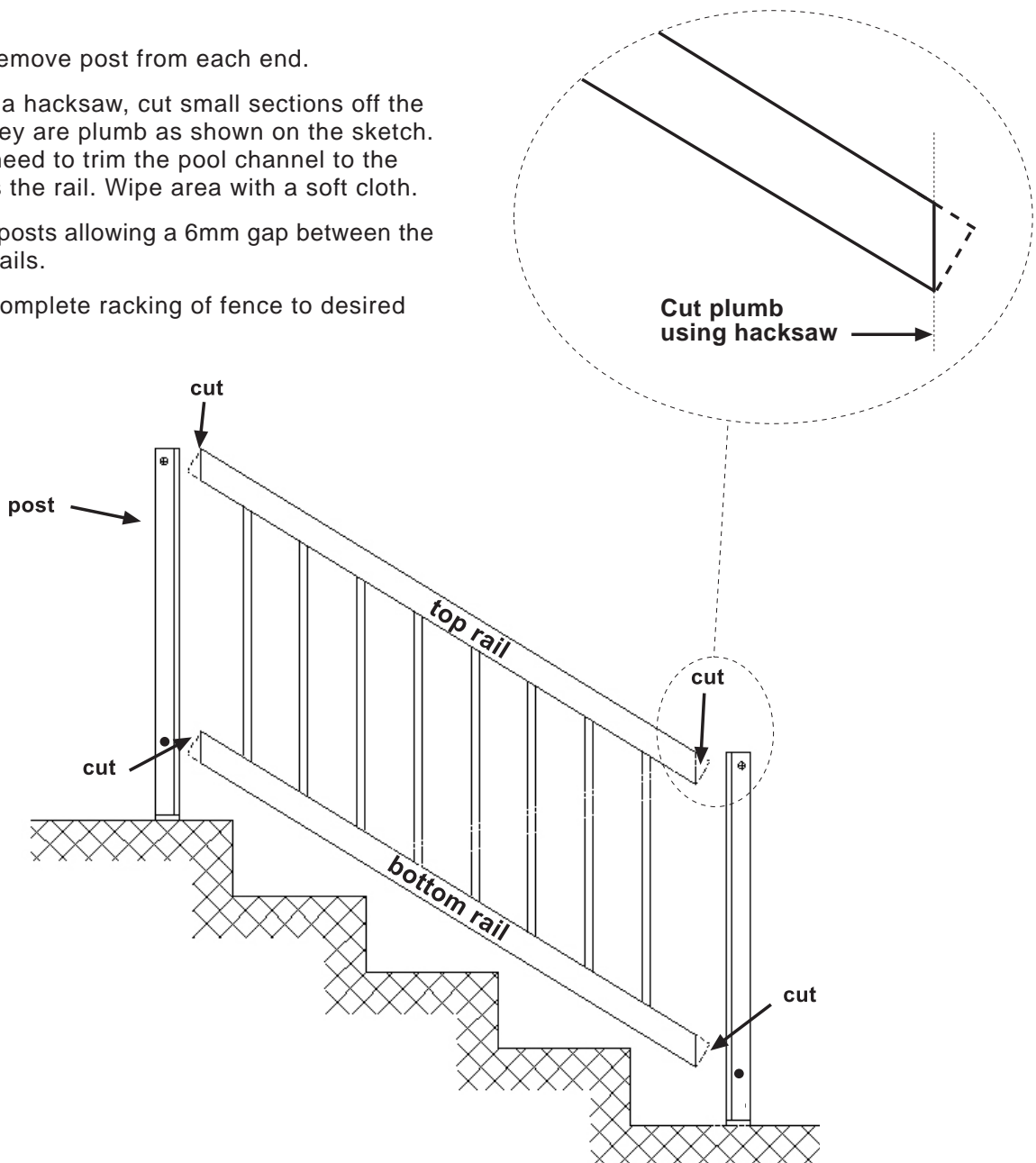

**METAL ROLLFORMING LIMITED**

PO BOX 18-217, AUCKLAND 1743, PHONE (09)527-7897, FAX (09)527-7896